



Power Line Communication: Powering Video Surveillance Infrastructure

By **Anees Ahmed** – Chairman & Co-Founder, Mistral Solutions Pvt. Ltd.

Introduction

The choice between distance and bandwidth, for a given budget, is one users and vendors constantly battle over when defining requirements and delivering solutions in video surveillance projects. Users would like the highest resolution video feeds delivered at their consoles at a price-point of a low bandwidth pipe: an expectation vendors struggle to meet.

In fixed video surveillance infrastructure projects, vendors do have some breathing space; afforded by the ability to lay new wiring at will (in most cases). In the case of temporary video surveillance infrastructure (or fixed infrastructure where laying new cables is not possible), though, this breathing space is reduced by the operational constraints in laying cable.

This brief will describe the concept of power line communication, and compare the technology to other alternatives such as wireless networking and PoE, especially when setting up temporary video surveillance local networks.

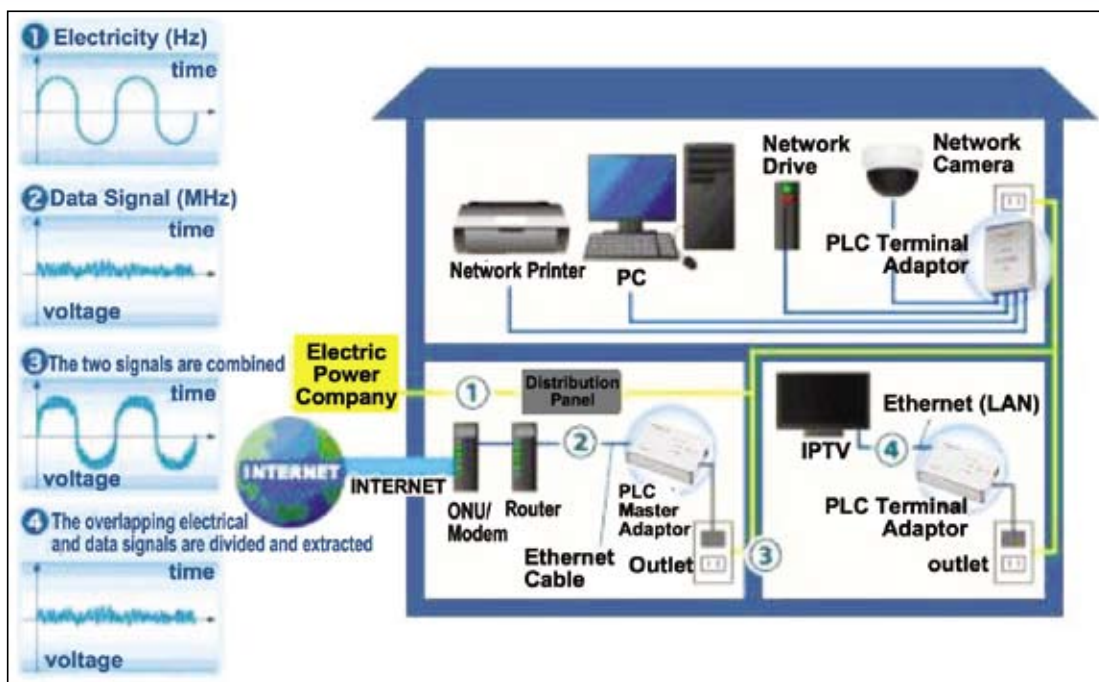

Figure 1: Power Line Communication (PLC) concept in a home, Credit: HD-PLC Alliance, www.hd-plc.org

What is Power Line Communication?

Power Line Communication (PLC), or Broadband over Powerline (BPL) or Powerline Networking (PLN), is a concept that describes using electric power transmission lines to carry data. The data can be carried within the power transmission network in a house or a premises, or between the premises and the power distribution network. PLC can be used for setting up a LAN (as a replacement or complement to a traditional Ethernet or Wi-fi LAN) or for

establishing a data connection between an intelligent edge device and its administrator (as, for example, between an intelligent electricity meter and the utility provider).

In practice PLC implementations are categorized as home or premises network requirements (high-to-medium bandwidth), and outside-the-home requirements (low bandwidth). There are a couple of conflicting standards governing PLC, and this confusion of standards has been a reason for the poor adoption of PLC in the market. The dominant PLC standards in the market are:

- IEEE 1901.
- ITU-T (International Telecommunication Union Telecommunication Standardisation Sector) G.hn.

IEEE 1901

The IEEE 1901 standards define the technology for high-speed power line communications. The standards defines methods for both in-home networking and access networking (Internet access). The IEEE 1901.2010 standard consolidated two existing standards in the market – FFT OFDM modulation (mainly in use in the USA) and Wavelet OFDM modulation (restricted to Japan).

This necessitated that two physical layers had to be specified, with vendors not required to offer both in their products; which meant that devices conforming to the IEEE 1901.2010 standard could, potentially, be incompatible with each other. Opponents of the IEEE 1901 standards point to this problem as a serious limitation to widespread market acceptance.

The market-ready products conforming to IEEE 1901 are best known as the HomePlug AV, in the USA, and HD-PLC, in Japan. The HomePlug AV is better known in the market, and the product categories available through the alliance are:

HomePlug AV and AV2

HomePlug AV offers a peak throughput of 200 Mbps and an

effective data rate of 80 Mbps. It is seen as an alternative to Fast Ethernet. HomePlug AV2 ups the peak throughput to 700 Mbps and the effective data rate to 350 Mbps, and is

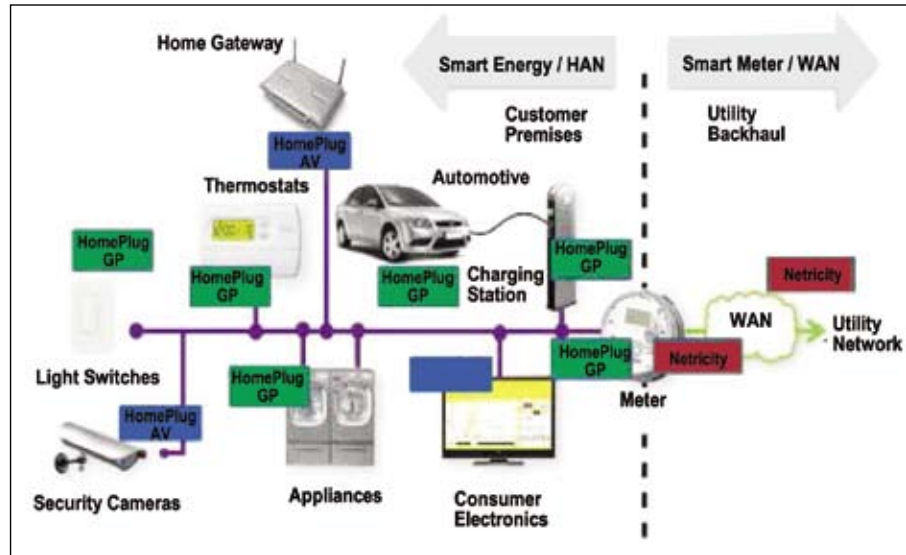

Figure 2: HomePlug Powerline Alliance Standards, Credit: HomePlug Alliance – www.homeplug.org

seen as an alternative to Gigabit Ethernet.

HomePlug GP

HomePlug Green PHY (GP) is a low-cost, low power-consumption standard meant for smart-grid and smart-meter applications. It offers peak rates of 10 Mbps.

Netricity PLC

Netricity PLC looks to address the need for longer range powerline networking for outside-the-home, smart grid and industrial applications. Netricity PLC will operate in low



Figure 3: Typical G.hn implementation, Credit: Lantiq Holdco S.a.r.l – www.lantiq.com

frequency bands that make it ideal for grid-to-utility meter and other long range, outside-the-home applications.

ITU-T G.hn

Unlike IEEE 1901, which focuses only on PLC, the ITU-T G.hn standard defines networking over power lines, phone lines, and co-ax cables, with data rates up to 1 Gbps. G.hn is a home network standard, as opposed to being

Use-cases for PLC

The table below summarises the use-cases and networking alternatives for video surveillance requirements. Before doing so, though, there are a couple of facts to note, about PLC:

- The range for PLC is up to 300 metres.
- The bandwidth mentioned against the various standards is not dedicated to a device, but shared among devices

Use-cases	PoE (Power-over-Ethernet) Twisted Pair	PoE (Power-over-Ethernet) Fibre	Wi-fi (with battery-powered cameras)	MoCA (Multimedia over Co-Ax)	PLC
Existing fixed infrastructure, looking to upgrade from analogue to IP video surveillance with minimal new cabling	No	No	No	Yes	Yes
New fixed infrastructure with IP PTZ cameras, and restrictions on cable-laying	No	No	No	No	Yes
Temporary infrastructure with IP PTZ cameras	No	No	No	No	Yes
Temporary infrastructure with IP fixed cameras, within a range of 100 metres	Yes	No	Yes	No	No
Temporary infrastructure with IP fixed cameras, beyond a range of 100 metres (and less than 300 metres)	No	Yes	Perhaps	No	Yes
Temporary infrastructure with IP battery-operated fixed cameras, where Wi-fi range is a problem	Yes	Yes	No	No	Yes

Table 1: Use-cases for the deployment of PLC in video surveillance projects

just a PLC standard, and targets using a mix of existing wiring in a typical home, to deliver a unified network.

The G.hn standard is promoted by the HomeGrid Forum; a trade group of vendors developing and marketing products based on the G.hn standard. The HomeGrid Forum claims that G.hn will deliver three to five times the throughput of competing powerline, co-ax, and phonenumber networking technologies, in real life conditions.

At CES 2012, in January, the HomeGrid Forum publicly demonstrated multi-vendor G.hn interoperability across the various media – powerline, phone and co-ax – thus signalling the imminent release of products based on the standard.

in the network.

- A PLC adapter typically costs anywhere between Rs.8,000/- to Rs.10,000/- for each device in the network.

Conclusion

Although PLC is gaining momentum in developed countries, the concept is still relatively untested in India. As can be seen, there are specific use-cases for the application of PLC in India, based on a cost-benefit analysis of the various alternatives.

Mistral offers wireless and wired IP video surveillance camera solutions, catering to various user requirements. ■